



Air heating unit

www.xvent.cz

 TACAMA

Clean design high heating capacity intuitive control EC motor

**Ideal for heating
industrial halls, warehouses,
sports facilities, workshops
and smaller facilities.**

Option to instal on the wall and on the ceiling with a tilt adjustment option of +30, 60° thanks to the console included in the package.

Silent operation and high efficiency.

Reliable and maintenance-fans for long-term operation.

Filter (accessories) is used to **protect** heat exchanger from **clogging**.

Thanks to speed regulation, the **optimum heating power can be selected**.

The use of high-quality components makes it possible to provide a **warranty for 5 years**.

The powder coating protection ensures excellent resistance even in an aggressive environment.

Both appealing and valued design, as well as **excellent operational properties supported by CFD simulations**.



Connecting the exchanger to the external G 3/4" thread (peak working conditions 120 °C, 1.6 MPa). Integrated venting valves on the water inlet and outlet.

Robust mounting console for **attachment to the wall and ceiling**. Delivered with the unit as a standard accessory. Its smart design allows easy installation of the unit **by only one worker**.

Fan with EC motor. Higher performance and low operating costs. Low noise level even at higher power output of the unit, Fan speed continuously adjustable from 20% to 100%.

Manually adjustable louvers allow individual air flow direction to be adjusted.

High-quality powder-coated copper exchanger in double and triple-row designs with an output of between **3 and 71 kW**.

Why is ATACAMY optimal and how to use it...

Using computer simulations (Computational Fluid Dynamics – mathematical-physical numerical gas flow solutions) in **typified spaces** based on real **installations**, we have reached the optimal unit shape.

Air output

up to 4900 m³/h

Heating capacity

2-71 kW

Horizontal blow range

up to 18 m

Vertical blow range

up to 11 m

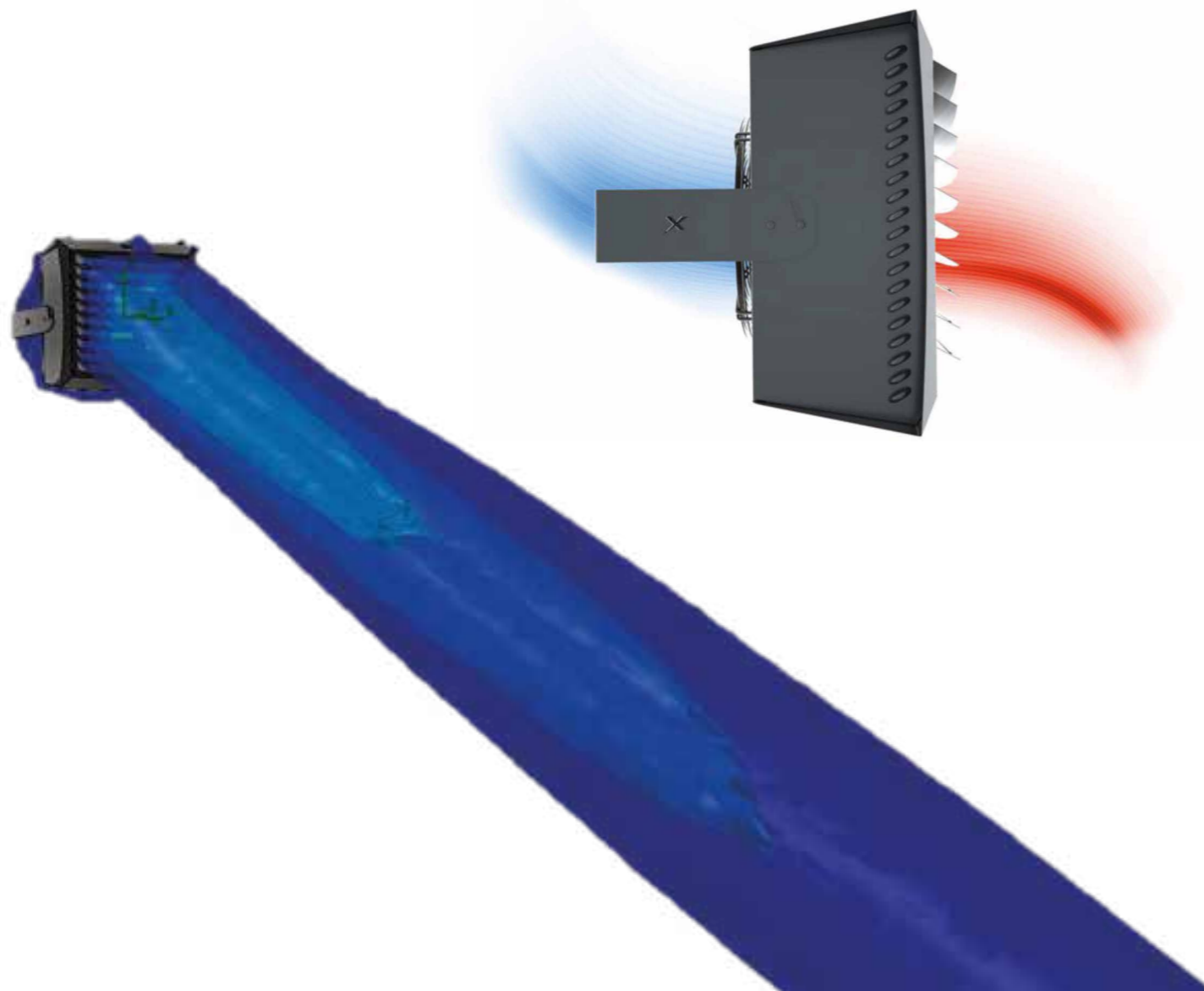

Frequently Asked Questions & Answers

Why is fan power adjustment important?

EC motor power adjustment is necessary feature for setting the required performance of the equipment. This parameter is used as a basis for other parameters of the equipment, which influence the working comfort in the given area - such as air output, temperature and noise level. Electricity consumption, depending on the life cycle of the unit, is no less important of a parameter.

How does the heating work?

Air heating is one of the most dynamic heating systems. Air heating is a system where the heat energy is supplied to the heated room exclusively via the flowing hot air from the unit. The principle of functioning of the hot air unit is based on the heat transfer the water exchanger to the surrounding air. Using an axial fan, the air is distributed to the heated space. Air heating is suitable for spaces where a radiant heat source is not desirable.

Why is heating power adjustment important?

Heating power of the units is the most important parameter for the economical operation of heating of the building. A room thermostat or temperature sensor is required for correct functionality of temperature control. The placement of the thermostat in the general presence zone outside of the door, window openings and sources of radiant heat at a height of approximately 1.5 m (reference point) is very important.

What is the meaning of the terms “mixing”, “destratification of mixing”, “venting”...?

Mixing or destratification is the principle of mixing the air with the result of an effective temperature distribution throughout the whole volume of space (the warmer air at the ceiling is mixed with colder air at the floor).





The ATACAMA Destratification Unit

Ensures **even distribution of the air temperature across the entire building height and reduces energy consumption.**

The equalization of the temperatures at the ceiling and at the floor is called **destratification**. Heat, which rises up to the ceiling, is re-circulated by the ATACAMA towards the floor, increasing the air temperature in the area of personal movement. This reduces energy consumption in the given area.



The energy saving with this solution is up to 15%, depending on the height the ceiling.

No destratification

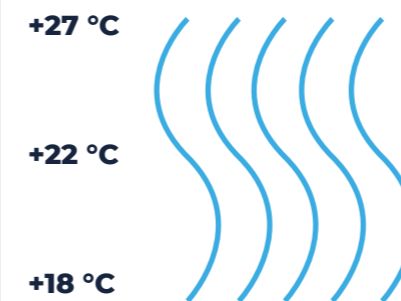

With destratification



Thanks to destratification, the heat comes back towards the floor.

How to install ATACAMA heating units?

Wall mounting is carried out using a commonly supplied console. In order to better direct the air stream, the unit on the console can be rotated at angles of 0°, 30° or 60° downwards.

Ceiling mounting can be carried out using a standard-supplied console or with four M6 threaded rods (not included in the delivery).

For the correct operation of the units, its distance from the wall (ceiling) must be least 0.2 m.

Wall-mounted - chained

(= using multiple units controlled together)



Ceiling - mounted

Using a console or threaded bars



On the wall

Turning option (0°, 30°, 60°)

How to install ATACAMA destratification units?

Atacama destratification units are mounted vertically onto the ceiling using commonly supplied console or M6 threaded rods.

The suitable place to install destratifier is as close to the ceiling as possible.

For correct operation of the unit, its distance from the ceiling must be at least 0.2 m.

Ceiling-mounted - chained

(= using multiple units controlled together)

Ceiling - mounted

Using a console or threaded bars

Ceiling - mounted

Using a console or threaded bars

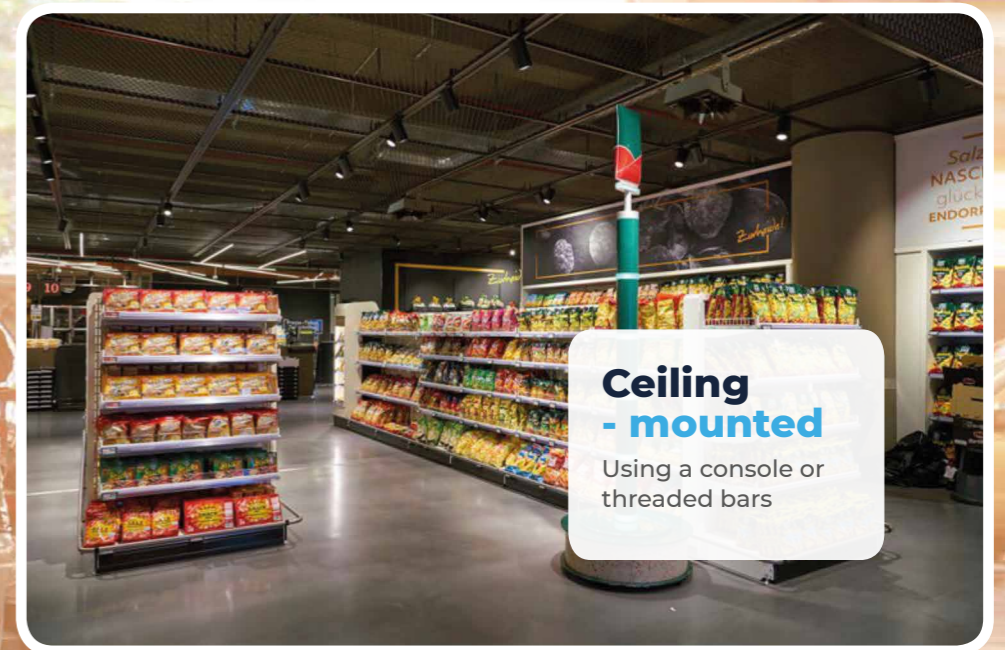
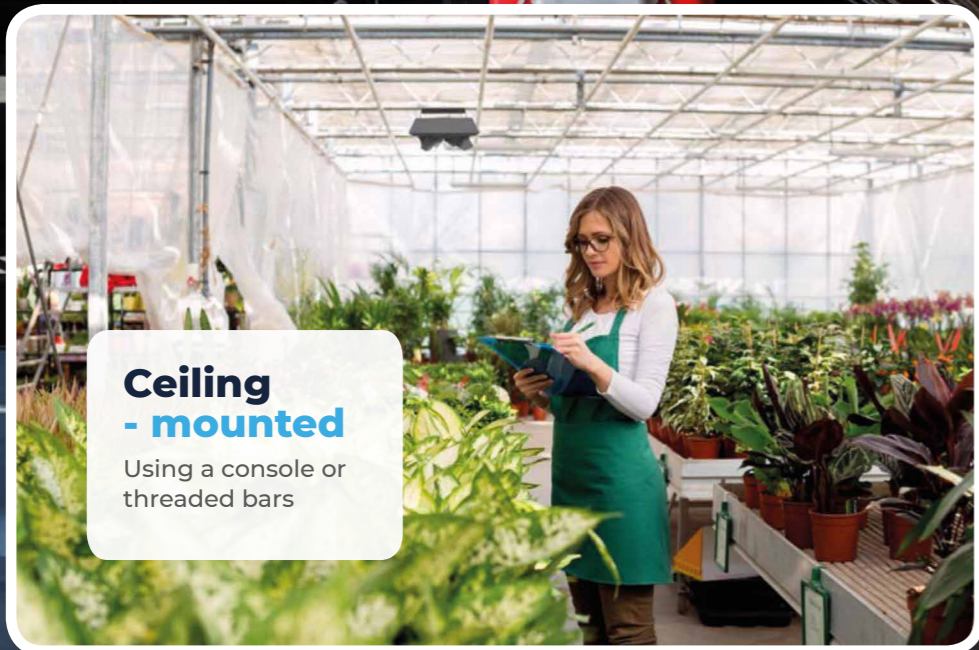

Accessories for the ATACAMA unit



Controls for the EC fans

- Continuous adjustment of fan speed with a 0-10V DC signal
- Integrated room thermostat
- Option to connect a control fixture with on/off drive
- Independent on/off heating control
- Fan deactivation upon reaching the required temperature

Motor type in the unit	EC
Input voltage	1 ~ 230/50-60
Output signal	0-10 V
Permissible load	0,02 A
Temperature adj. range	5-35 °C
Temperature sensor	integrated
Cover	IP20
Package dimensions (height x width x depth)	85 x 85 x 30 mm
Gross weight	0.25 kg
Net weight	0.2 kg
Sales code	ELEMENTAIR-E-M1



Servo-driven valve

Allows you to switch water on/off based on the temperature measured by the thermostat.

Power supply	230/50-60 V/Hz
Power consumption	2 W
Connection dimension	3/4"
Maximum medium temperature	120 °C
Maximum ambient temperature	50 °C
Cover - in any position	IP 44
Gross weight	0.3 kg
Net weight	0.3 kg
Package dimensions (height x width x depth)	120 x 120 x 120
Sales code	„MTA-230-NC V2050DH025“



Filter

The fan intake filter is used to collect rougher dust particles, making the room environment is cleaner for persons at the place of installation.

Unit size	ATACAMA 2,3	ATACAMA 4
Filtration class	G2 (ISO Coarse)	G2 (ISO Coarse)
Gross weight	0.1 kg	
Net weight	0.1 kg	
Package dimensions (height x width x depth)	300 x 220 x 50	
Sales code	FILTER-350	FILTER-450

How can the ATACAMA unit be connected?

Examples of hydraulic connections with Xvent EC motor accessories

1	Atacama
2	Speed controls with thermostat
3	Da-aeration valve - a part of the exchanger
4	Flexible hoses
5	Shutter valve
6	Two-way fixture
7	Filter
8	Pump
9	Hot water source

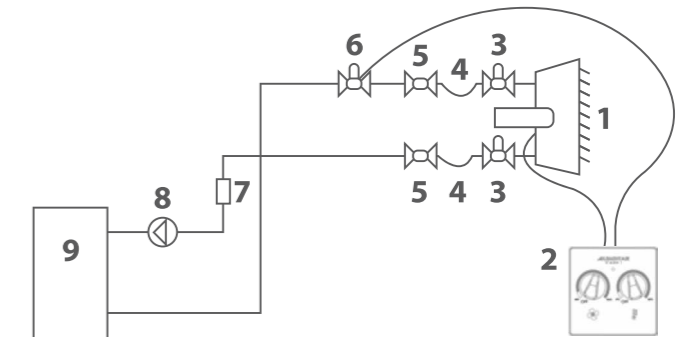

Examples of electrical connections with the Xvent EC motor accessory

1	Atacama
2	Speed controls with thermostat
3	Thermoelectric-driven valve
4	230V/50Hz power supply

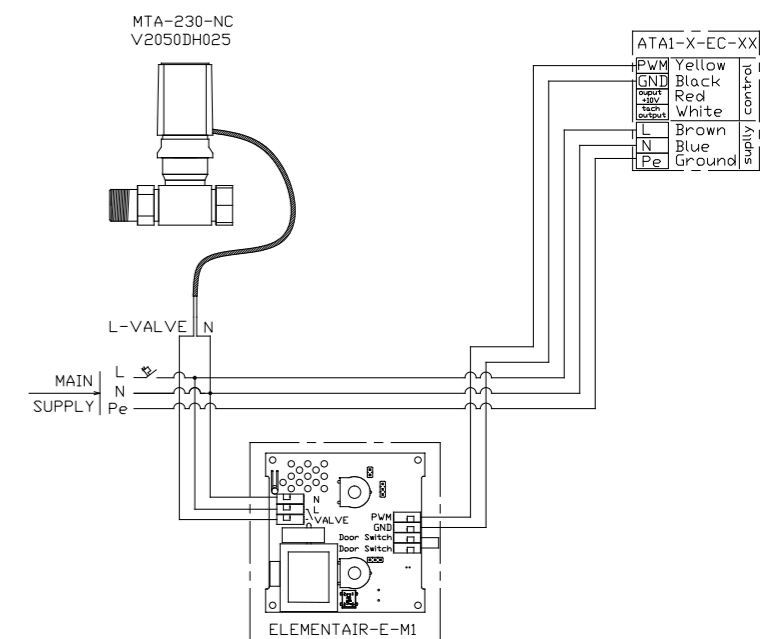

Description of the Elementair-E regulator

Continuous fan speed adjustment with the main switch
 - enables smooth adjustment of the fan speed in any position from the minimum to the maximum fan speed as required by the user. The end position „OFF“ allows the entire regulator to be switched off. The „OFF“ position does not actually disconnect the controlled equipment from the supply voltage - it must be ensured separately at the supply.



Indicator diode - indicates the operation of the entire regulator. If the diode is lit, the regulator is active. If the regulator is not on, the diode is switched off.

Room thermostat
 - allows setting of the required temperature in the range of 5 to 35 °C. Based on the difference between the ambient temperature and the required temperature, the connected equipment is switched off or switched on. It also has the option to use the „OFF“ end position to disable the room thermostat.

Description of controller elements - Elementair-E Mark I

Continuous fan speed regulator – allows smooth fan speed adjustment in any position from minimum to maximum fan speed as required by the user. It also has the option to use the „OFF“ end position to disable the room thermostat. The „OFF“ position does not actually disconnect the controlled equipment from the supply voltage – it must be ensured separately at the supply.

Room thermostat – allows setting of the required temperature from 5 to 35°C. Based on the difference between the ambient temperature and the required temperature, the fan is switched off or on. It also has the option to use the „OFF“ end position to disable the room thermostat.

Indicator diode – indicates the operation of the entire regulator. If the diode is lit, the regulator is active. If the regulator is not on, the diode is switched off.

Description of the logic of the regulation:

- The room temperature is lower than the temperature setting – set by the user on the room thermostat.
 - The fan runs at the speed set by the user. When the required temperature is reached, the fan is switched off.
 - The drive fixture is opened – the unit is heating. The fixture control is in the switching logic relationship with the fan. The fan is switched off, the fixture is closed.
- The room thermostat is in the OFF position, the fan is continuously running at the speed set by the user – it is not switched off. The drive fixture is closed.
- The speed regulator is in the OFF position, the unit is switched off.

The regulator must be connected as per the recommended electrical diagram. Electrical wiring may only be carried out only by persons with the appropriate authorisation and in accordance with the applicable local regulations.

Recommended accessories for the ATACAMA heating unit connected to the regulator - Elementair-E Mark I

- V2050DH025 - (2 -way fixture, 1" valve)
 - MTA-230-NC - (thermoelectric drive for the fitting)
- Allows to close/open the heating water supply.

Options for chaining units to one regulator:

The following may be connected to one regulator:

ATAI-3-EC	8 units
ATAI-4-EC	8 units

Recommended electrical connection of the Elementair-E Mark I regulator

Example diagram of regulator wiring with heating and the ATACAMA destratification unit

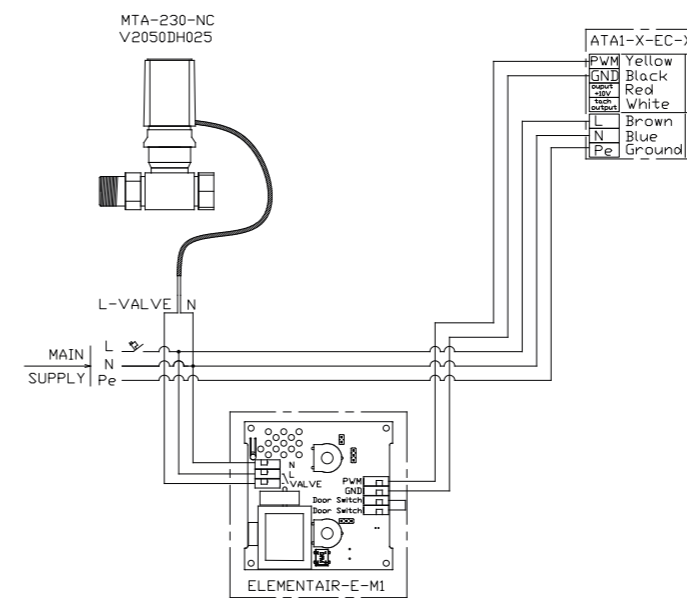

Wiring diagram of chained ATACAMA heating and destratification units - with regulator only

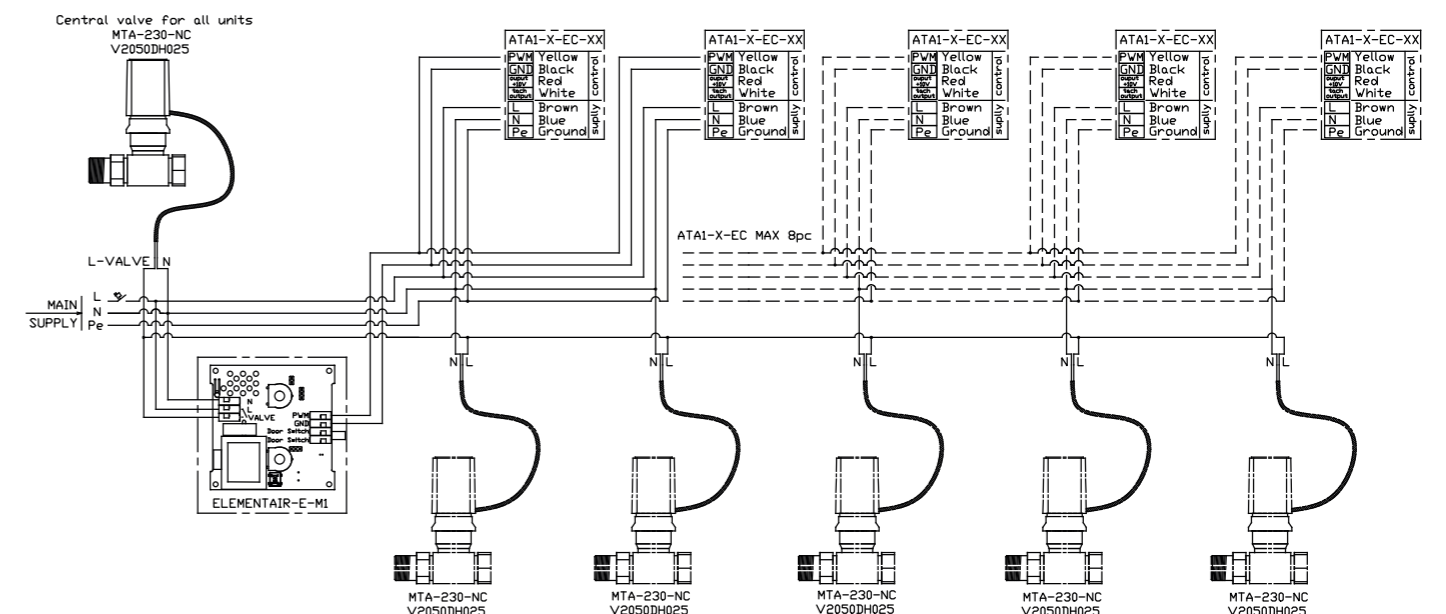

Technical parameters ATACAMA Heating unit



ATACAMA 2 and 3
565 mm

ATACAMA 4
655 mm

Heat exchanger parameters:

Max. operating water temperature 120°C
Max. operating pressure 1.6 Mpa
Connecting dimensions of all heat exchangers external thread G 3/4".

Comparison of consumption

● AC ● EC

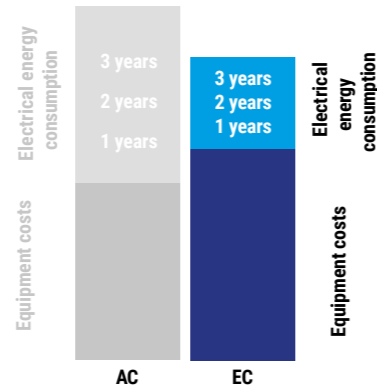
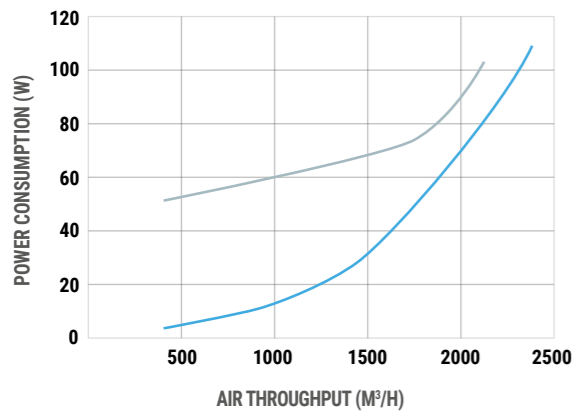

ATACAMA 2 and 3
605 mm

ATACAMA 4
695 mm

ATACAMA 2 and 3
470 mm

ATACAMA 4
470 mm

Packaging

	Code	Weight		Package size *	max. number of units on the pallet** / max. stack capacity
		Brutto	Netto		
		kg	kg	m	ks
ATACAMA 3	ATA1-3-ECV1CL-0-A-0	19,6	15	0,59x0,73x0,35	8/4
	ATA1-3-ECV2CL-0-A-0	21,6	17		
	ATA1-3-ECV3CL-0-A-0	22,6	18		
ATACAMA 4	ATA1-4-ECV1CL-0-A-0	26,2	21	0,69x0,87x0,35	8/4
	ATA1-4-ECV2CL-0-A-0	28,2	23		
	ATA1-4-ECV3CL-0-A-0	30,2	25		
	ATA1-4-ECV4CL-0-A-0	33,2	28		

*The package size is indicated in the order of width x length x height

**Refers to a standard EURO pallet with dimensions of 0.8x1.2x0.144 mm

Dependence of air on distance

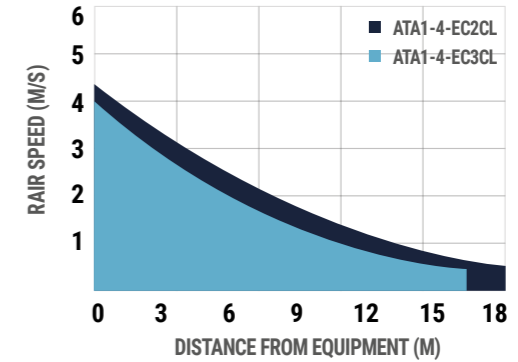
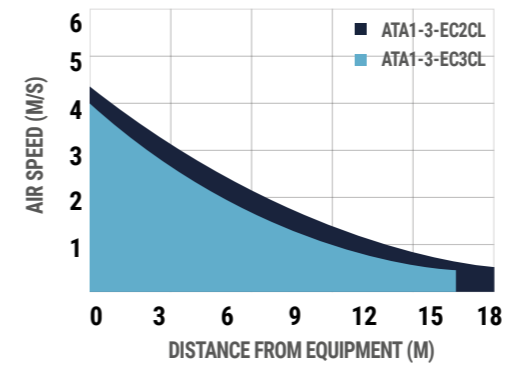

Technical data

		ATACAMA 3			ATACAMA 4			
		EC			EC			
Fan type	-	EC			EC			
Operating area (ceiling height 4m)	m ²	0-500			0-1000			
Air flow	m ³ /h	3200	3000	2600	4900	4700	4400	4000
Heat output range	kW	2 - 20	4 - 38	5 - 44	4 - 29	9 - 58	11 - 71	12 - 83
Cooling output (7°C/12°C)/30°C	kW	-	-	-	-	-	18,1	22,1
Number of exchanger rows	-	1	2	3	1	2	3	4
Working information of exchanger								
Maximal horizontal range *	m	18	17	14	16	15	12	10
Maximal vertical range *	m	11	10	8	9	8	6	5
Noise level **	dB(A)	42	42,3	42,1	51,5	52,1	51,6	51
Unit weight with bracket***	kg	14 / 16,5	15 / 17,5	16 / 18,5	21 / 24	23 / 26	25 / 28	28 / 31
Capacity of water in exchanger	dm ³	0,8	1,4	2,1	1	2	3	4
Power supply	V/Hz	1 ~ 230/50-60			1 ~ 230/50-60			
Motor output	W	114	114	117	359	359	379	381
Motor current	A	0,86	0,86	0,9	1,53	1,53	1,63	1,65
Otáčky	ot/min	1790			1310			
IP range	IP	54			54			
Sales code	-	ATA1-3-ECVCL-0A0	ATA1-3-ECV2CL-0A0	ATA1-3-ECV3CL-0A0	ATA1-4-ECV1CL-0A0	ATA1-4-ECV2CL-0A0	ATA1-4-ECV3CL-0A0	ATA1-4-ECV4CL-0A0

* Maximum range of air flow at 0,5m/s air speed

** Sound pressure level in 5m, Q=2

*** Unit weight, no water

Each package contains:

- Unit
- Unit suspension bracket
- Connecting material for unit and bracket connection
- Simplified installation manual (full manual available at www.xvent.cz)
- Information on safe use of the product

ATAI-3-ECV1CL , ATAI-3-ECV2CL

ATACAMA 3 – EC variant

Fan speed *	Air power	Current units	Power input units	Acoustic power in frequency bands (dB)								Noise level	
				63 Hz	125 Hz	250 Hz	500 Hz	1 kHz	2 kHz	4 kHz	8 kHz	LwA	LPA*
	m³/h	A/230V/Hz	W	dB	dB	dB	dB	dB	dB	dB	dB	dB	dB
III	3000	1.33/230/50-60	184	37.7	55.7	68.4	71.3	72.0	70.5	65.0	55.2	77.1	51.7
II	2000	0.51/230/50-60	66	34.4	47.9	59.9	62.2	63.2	62.0	55.0	43.6	68.3	42.9
I	750	0.08/230/50-60	6	17.8	28.4	36.9	40.7	39.1	33.8	27.5	19.8	44.6	19.2

*The specified air flow rates correspond to the maximum, mean and minimum flow rates

** Sound pressure level in 5m, Q=2

ATAI-3-ECV3CL

ATACAMA 3 – EC variant

Fan speed *	Air power	Current units	Power input units	Acoustic power in frequency bands (dB)								Noise level	
				63 Hz	125 Hz	250 Hz	500 Hz	1 kHz	2 kHz	4 kHz	8 kHz	LwA	LPA*
	m³/h	A/230V/Hz	W	dB	dB	dB	dB	dB	dB	dB	dB	dB	dB
III	2600	1.41/230/50-60	189	36.9	55.0	66.3	69.8	70.5	69.3	64.6	54.1	75.7	50.3
II	1900	0.59/230/50-60	74	34.0	47.7	59.1	61.4	62.7	61.6	55.5	43.5	67.8	42.4
I	700	0.08/230/50-60	6	18.9	28.0	37.6	40.0	38.9	32.8	25.7	18.2	44.2	18.9

*The specified air flow rates correspond to the maximum, mean and minimum flow rates

** Sound pressure level in 5m, Q=2

ATAI-4-ECV1CL , ATAI-4-ECV2CL

ATACAMA 4 – EC variant

Fan speed *	Air power	Current units	Power input units	Acoustic power in frequency bands (dB)								Noise level	
				63 Hz	125 Hz	250 Hz	500 Hz	1 kHz	2 kHz	4 kHz	8 kHz	LwA	LPA*
	m³/h	A/230V/Hz	W	dB	dB	dB	dB	dB	dB	dB	dB	dB	dB
III	4700	1.53/230/50-60	359	41.3	59.6	67.3	70.3	72.2	72.3	66.7	57.2	77.5	52.1
II	3500	0.69/230/50-60	161	38.7	47.8	56.9	63.5	65.4	64.8	58.0	46.3	70.0	44.6
I	1950	0.20/230/50-60	41	26.3	34.7	43.6	49.2	52.3	50.0	38.0	24.8	55.9	30.5

*The specified air flow rates correspond to the maximum, mean and minimum flow rates

** Sound pressure level in 5m, Q=2

ATAI-4-ECV3CL

ATACAMA 4 – EC variant

Fan speed *	Air power	Current units	Power input units	Acoustic power in frequency bands (dB)								Noise level	
				63 Hz	125 Hz	250 Hz	500 Hz	1 kHz	2 kHz	4 kHz	8 kHz	LwA	LPA*
	m³/h	A/230V/Hz	W	dB	dB	dB	dB	dB	dB	dB	dB	dB	dB
III	4400	1.63/230/50-60	379	42.1	60.4	64.7	70.2	72.0	71.8	66.5	57.2	77.0	51.6
II	3150	0.70/230/50-60	164	39.8	48.3	56.8	65.6	65.3	64.5	59.3	47.4	70.5	45.1
I	1800	0.20/230/50-60	42	28.1	38.9	48.7	52.4	56.0	54.4	46.4	32.8	59.9	34.5

*The specified air flow rates correspond to the maximum, mean and minimum flow rates

** Sound pressure level in 5m, Q=2

Water heater parameters



ATAI-4-ECV3CL - COOLING

ATACAMA 4 – EC TYPE

Inlet air temperature - 50%RH	Air flow	7/12			
		Heating capacity of the heater	Exhaust air temperature	Water flow	Pressure loss - water
°C	m³/h	kW	°C	m³/h	kPa
25	4400	14,5	16,1	2,5	45,8
	3150	12	15	1,17	32,7
	1800	8,6	13,3	0,83	19,9
27	4400	17,8	17	3,06	59,3
	3150	14,9	15,8	2,56	48,3
	1800	10,7	13,8	1,84	29,6
29	4400	21,7	17,9	3,73	84,9
	3150	18,2	16,6	3,13	61,9
	1800	13,1	14,3	2,25	38,1

ATAI-4-ECV4CL - COOLING

ATACAMA 4 – EC TYPE

Inlet air temperature - 50%RH	Air flow	7/12			
		Heating capacity of the heater	Exhaust air temperature	Water flow	Pressure loss - water
°C	m³/h	kW	°C	m³/h	kPa
25	4000	16,8	14,3	2,88	35,9
	2800	13,51	13,2	2,32	28,6
	1600	9,3	11,6	1,6	16,9
27	4000	20,76	14,9	1,56	52,7
	2800	16,7	13,7	1,26	35,8
	1600	11,5	11,8	0,87	25,2
29	4000	25,29	15,6	4,34	75,4
	2800	20,5	14,1	3,51	51,3
	1600	14	12	2,41	30,6

Water heater parameters



ATAI-3-ECV1CL - HEATING

ATACAMA 3 – EC variant

Inlet air temperature	Air flow	90/70				80/60				70/50				60/40				50/30			
		Heating capacity of the heater	Exhaust air temperature	Water flow	Pressure loss - water	Heating capacity of the heater	Exhaust air temperature	Water flow	Pressure loss - water	Heating capacity of the heater	Exhaust air temperature	Water flow	Pressure loss - water	Heating capacity of the heater	Exhaust air temperature	Water flow	Pressure loss - water	Heating capacity of the heater	Exhaust air temperature	Water flow	Pressure loss - water
°C	m3/h	kW	°C	m3/h	kPa	kW	°C	m3/h	kPa	kW	°C	m3/h	kPa	kW	°C	m3/h	kPa	kW	°C	m3/h	kPa
5	3200	18,48	21,3	0,82	20,6	15,6	18,8	0,69	15,2	12,72	16,2	0,56	10,5	9,82	13,7	0,43	15	6,91	11,1	0,3	7,9
	2100	15,84	26,3	0,93	15,4	13,4	23	0,59	11,4	10,94	19,7	0,48	7,9	8,48	16,4	0,37	11,4	5,99	13	0,26	6,1
	800	10,32	41,4	0,46	6,9	8,77	35,9	0,39	11,8	7,2	30,4	0,32	8,3	5,63	24,9	0,25	5,3	3,89	18,7	0,17	2,7
10	3200	17,06	25,3	0,76	17,7	14,2	22,7	0,63	12,7	11,33	20,2	0,5	8,5	8,45	17,6	0,37	11,3	5,55	15	0,24	5,3
	2100	14,62	30	0,65	13,3	12,2	26,7	0,54	9,6	9,75	23,3	0,43	14,6	7,3	20	0,32	8,6	4,75	16,5	0,21	3,9
	800	9,52	44,2	0,42	13,6	7,98	38,6	0,35	9,9	6,43	33,1	0,28	6,7	4,87	27,5	0,21	4,1	3,02	20,8	0,13	1,7
15	3200	15,65	29,3	0,69	15,1	12,8	26,7	0,57	10,5	9,94	24,1	0,44	6,6	7,09	21,5	0,31	8,2	3,94	18,6	0,17	2,8
	2100	13,41	33,6	0,6	11,3	10,99	30,3	0,49	7,9	8,57	26,9	0,38	11,5	6,13	23,5	0,27	6,2	3,32	19,6	0,14	2
	800	8,73	46,9	0,39	11,6	7,2	41,3	0,32	8,2	5,66	35,7	0,25	5,3	4,08	29,9	0,18	2,9	2,24	23,2	0,1	1
18	3200	14,9	31,6	0,66	13,8	12	29	0,53	9,4	9,18	26,3	0,4	13	6,31	23,7	0,28	6,6	2,93	20,7	0,13	1,6
	2100	12,7	35,7	0,57	10,3	10	32,3	0,46	7,3	7,9	29	0,35	9,9	5,47	25,6	0,24	5,1	2,55	21,6	0,11	1,3
	800	8,33	48,3	0,37	10,6	6,3	42,7	0,3	7,1	5,2	37,1	0,23	4,6	3,59	31,1	0,16	2,3	1,82	24,7	0,08	0,6

- the air flow rates indicated correspond to the maximum, mean and minimum flow rates

ATAI-3-ECV2CL - HEATING

ATACAMA 3 – PROVEDENÍ EC

Inlet air temperature	Air flow	90/70				80/60				70/50				60/40				50/30			
		Heating capacity of the heater	Exhaust air temperature	Water flow	Pressure loss - water	Heating capacity of the heater	Exhaust air temperature	Water flow	Pressure loss - water	Heating capacity of the heater	Exhaust air temperature	Water flow	Pressure loss - water	Heating capacity of the heater	Exhaust air temperature	Water flow	Pressure loss - water	Heating capacity of the heater	Exhaust air temperature	Water flow	Pressure loss - water
°C	m3/h	kW	°C	m3/h	kPa	kW	°C	m3/h	kPa	kW	°C	m3/h	kPa	kW	°C	m3/h	kPa	kW	°C	m3/h	kPa
5	3000	35,2	42,6	1,55	30	30,4	36,9	1,34	25	25,5	31,3	1,12	19	20,4	25,7	0,89	13	15,2	20	0,66	8
	2000	26,7	48,7	1,18	18	23,2	42,2	1,02	15	19,6	35,7	0,86	12	15,8	29,2	0,69	8	11,8	22,8	0,51	5
	750	12,8	62,9	0,53	6	11,2	54,5	0,49	4	9,61	46,2	0,42	3	7,87	37,9	0,34	2	6,02	29,5	0,26	1
10	3000	32,5	45,1	1,43	26	27,8	39,4	1,22	20	22,9	33,8	1	15	17,8	28,1	0,77	10	12,5	22,5	0,54	5
	2000	24,8	50,8	1,09	17	21,2	44,2	0,93	13	17,6	37,7	0,77	10	13,8	31,3	0,6	6	9,78	24,8	0,42	3
	750	11,9	64	0,52	5	10,4	55,6	0,45	6	8,68	47,3	0,38	3	6,91	39	0,3	2	5,04	30,6	0,22	1
15	3000	30	47,6	1,32	22	25,2	41,9	1,11	18	20,3	36,2	0,89	12	15,1	30,6	0,66	7	9,82	24,9	0,43	4
	2000	22,8	42,8	1,01	15	19,3	46,3	0,85	11	15,6	39,8	0,68	8	11,8	33,3	0,51	5	7,75	26,8	0,34	2
	750	11	65,2	0,48	5	9,44	56,8	0,41	5	7,75	48,5	0,34	2	5,96	40,1	0,26	1	4,06	31,6	0,18	1
18	3000	31,7	45,8	1,41	28,6	26,27	40,5	1,16	24,4	19,16	36,9	0,84	13,9	13,64	31,5	0,6	10,8	8,05	25,9	0,35	10
	2000	25,13	51,7	1,12	22,1	20,8	45,4	0,92	15,9	15,31	40,6	0,67	13,1	11	34,2	0,48	7,2	6,47	27,6	0,28	6,7
	750	13,1	66,2	0,52	9,6	11	57,9	0,49	7	8,2	50,3	0,36	10	6	41,6	0,26	5,7	3,43	31,5	0,15	2,1

- the air flow rates indicated correspond to the maximum, mean and minimum flow rates

ATAI-3-ECV3CL - HEATING

ATACAMA 3 – EC variant

Inlet air temperature	90/70					80/60					70/50					60/40					50/30				
	Air flow	Heating capacity of the heater	Exhaust air temperature	Water flow	Pressure loss - water	Heating capacity of the heater	Exhaust air temperature	Water flow	Pressure loss - water	Heating capacity of the heater	Exhaust air temperature	Water flow	Pressure loss - water	Heating capacity of the heater	Exhaust air temperature	Water flow	Pressure loss - water	Heating capacity of the heater	Exhaust air temperature	Water flow	Pressure loss - water				
°C	m3/h	kW	°C	m3/h	kPa	kW	°C	m3/h	kPa	kW	°C	m3/h	kPa	kW	°C	m3/h	kPa	kW	°C	m3/h	kPa				
5	2600	40,5	57,5	1,79	28	35,5	49,8	1,56	23	30,2	42,2	1,32	19	24,6	34,6	1,07	15	18,7	26,9	0,81	9				
	1900	32	62,4	1,41	20	28,1	54,1	1,23	16	24	45,9	1,05	14	19,7	37,6	0,86	10	15,1	29,4	0,66	8				
	700	14	75,4	0,62	6	12,4	65,8	0,54	5	10,8	56	0,47	4	9,01	46,4	0,39	5	7,07	36,5	0,31	3				
10	2600	37,7	59	1,66	25	32,6	51,3	1,43	21	27,2	43,7	1,19	16	21,6	36,1	0,94	12	15,6	28,4	0,68	8				
	1900	29,8	63,6	1,31	17	25,8	55,3	1,13	14	21,7	47,1	0,95	11	17,3	38,8	0,75	10	12,6	30,5	0,55	5				
	700	13	75,8	0,57	5	11,5	66,2	0,51	4	9,82	56,5	0,43	5	7,99	46,8	0,35	4	5,99	36,8	0,26	2				
15	2600	34,9	60,5	1,54	23	29,7	52,8	1,3	18	24,3	45,2	1,06	14	18,6	37,6	0,81	9	12,5	29,8	0,54	5				
	1900	27,5	64,8	1,21	15	23,5	56,5	1,03	13	19,4	48,2	0,85	9	14,9	40	0,65	7	10,2	31,5	0,44	6				
	700	12,1	76,3	0,53	5	10,6	66,6	0,46	6	8,83	56,9	0,39	4	6,96	47,1	0,3	3	4,9	36,9	0,21	4				
18	2600	37,2	60	1,65	30,6	30,8	53	1,36	22	24,3	45,6	1,07	17,8	17,7	38,1	0,78	15,3	10,8	30,4	0,47	6,3				
	1900	30	64	1,34	20,7	25	56,8	1,1	18,4	19,8	48,8	0,87	12,2	15,5	40,6	0,64	10,6	9	32	0,39	11,7				
	700	14	77	0,63	9,5	11,8	67,8	0,52	7	9,5	58,1	0,42	12,5	7,1	48	0,31	7,4	4,3	36	0,19	3				

- the air flow rates indicated correspond to the maximum, mean and minimum flow rates

Water heater parameters



ATAI-4-ECV1CL - HEATING

ATACAMA 4 – EC variant

Inlet air temperature	Air flow	90/70				80/60				70/50				60/40				50/30			
		Heating capacity of the heater	Exhaust air temperature	Water flow	Pressure loss - water	Heating capacity of the heater	Exhaust air temperature	Water flow	Pressure loss - water	Heating capacity of the heater	Exhaust air temperature	Water flow	Pressure loss - water	Heating capacity of the heater	Exhaust air temperature	Water flow	Pressure loss - water	Heating capacity of the heater	Exhaust air temperature	Water flow	Pressure loss - water
°C	m3/h	kW	°C	m3/h	kPa	kW	°C	m3/h	kPa	kW	°C	m3/h	kPa	kW	°C	m3/h	kPa	kW	°C	m3/h	kPa
5	4900	26,51	20,3	1,18	14,4	18,4	15,6	0,81	13	18,08	15,4	0,79	12,7	13,82	13	0,6	7,8	9,57	10,5	0,42	12,5
	3600	23,8	23,6	1,06	11,7	16,57	18	0,73	10,7	16,24	17,7	0,71	10,4	12,46	14,8	0,55	6,4	8,6	11,7	0,37	10,2
	2000	18,9	31,6	0,84	7,6	13,34	23,8	0,59	7,1	12,98	23,3	0,57	6,8	10,01	19,1	0,44	4,2	6,69	14,4	0,29	6,4
10	4900	24,47	24,3	1,1	12,4	16,71	53,3	0,74	10,8	16,04	19,4	0,71	10,1	11,83	16,9	0,52	5,8	7,33	14,3	0,32	7,6
	3600	21,92	27,5	0,97	10,1	15,06	22	0,67	8,9	14,43	21,5	0,63	8,3	10,67	18,5	0,47	4,8	6,43	15,1	0,28	5,9
	2000	17,41	35	0,77	11,6	12,12	27,4	0,54	5,9	11,55	26,6	0,51	5,5	8,6	22,3	0,38	10,1	5,01	17,2	0,22	3,7
15	4900	22,4	28,3	0,99	10,5	15,05	24	0,66	8,9	14,04	23,4	0,62	7,9	9,87	20,9	0,43	4,1	4,81	17,9	0,21	3,5
	3600	20,09	31,3	0,89	8,5	13,59	26	0,6	7,3	12,64	25,2	0,56	6,5	8,91	22,2	0,39	10,8	4,34	18,5	0,19	2,9
	2000	15,9	38,3	0,71	9,8	10,93	30,9	0,48	4,9	10,12	29,8	0,45	4,3	7,16	25,4	0,31	7,2	3,57	20,2	16	2
18	4900	22,3	31,5	0,99	25,2	18,2	29	0,81	23,1	14	26,5	0,62	14,6	9,9	24	0,43	7,8	5,7	21,4	0,25	6,2
	3600	20	34,4	0,89	20,6	16,3	31,4	0,72	18,9	12,6	28,4	0,56	12	8,9	25,3	0,39	13,6	5,1	22	0,22	5
	2000	15,8	41,4	0,7	17,6	12,9	37,2	0,57	12,4	10,1	32,9	0,44	7,9	7,1	28,6	0,31	9,2	4	23,9	0,17	3,2

- the air flow rates indicated correspond to the maximum, mean and minimum flow rates

ATAI-4-ECV2CL - HEATING

Vstupní teplota vzduchu	Průtok vzduchu	90/70				80/60				70/50				60/40				50/30			
		Topný výkon ohřivače	Teplota vzduchu na výfuku	Průtok vody	Tlaková ztráta vody	Topný výkon ohřivače	Teplota vzduchu na výfuku	Průtok vody	Tlaková ztráta vody	Topný výkon ohřivače	Teplota vzduchu na výfuku	Průtok vody	Tlaková ztráta vody	Topný výkon ohřivače	Teplota vzduchu na výfuku	Průtok vody	Tlaková ztráta vody	Topný výkon ohřivače	Teplota vzduchu na výfuku	Průtok vody	Tlaková ztráta vody
°C	m3/h	kW	°C	m3/h	kPa	kW	°C	m3/h	kPa	kW	°C	m3/h	kPa	kW	°C	m3/h	kPa	kW	°C	m3/h	kPa
5	4700	53,9	41,8	2,38	43	49,7	36,3	2,05	34	39,2	30,8	1,72	25	31,5	25,3	1,37	19	23,5	19,9	1,02	13
	3500	44,4	46,2	1,96	30	38,6	40,1	1,69	24	32,5	34	1,42	20	26,2	27,9	1,14	14	19,7	21,9	0,85	9
	1950	29,2	55	1,29	16	25,5	47,6	1,12	14	21,7	40,4	0,95	11	17,7	33,2	0,77	7	13,5	25,9	0,58	6
10	4700	50	44,3	2,2	37	42,7	38,8	1,87	29	35,2	33,3	1,54	23	27,5	27,9	1,2	15	19,4	22,4	0,84	9
	3500	51,2	48,4	1,81	26	35,3	42,3	1,55	22	29,2	36,2	1,28	16	22,9	30,2	1	12	16,4	24,1	0,71	8
	1950	27,1	56,6	1,2	14	23,4	49,4	1,03	12	19,6	42,1	0,86	9	15,5	34,8	0,68	7	11,2	27,6	0,49	4
15	4700	46	46,9	2,03	32	38,7	41,3	1,7	24	31,2	35,9	1,37	18	23,5	30,4	1,02	12	15,4	24,9	0,67	7
	3500	38	50,7	1,67	23	32	44,6	1,41	19	25,9	38,5	1,14	13	19,6	32,4	0,85	9	12,9	26,3	0,56	5
	1950	25,1	58,3	1,1	13	21,3	51	0,94	10	17,4	43,7	0,76	9	13,3	36,5	0,58	6	8,95	29,1	0,39	5
18	4700	45,3	46,5	2,02	41,1	37,2	41,4	1,65	29	29,1	36,3	1,28	23,6	20,9	31,1	0,92	13	12,4	25,8	0,54	7,9
	3500	38,5	50,5	1,7	30,3	31,7	44,8	1,4	21,6	24,8	39	1,09	17,6	17,9	33,1	0,78	15,3	10,7	27,1	0,47	6,1
	1950	26,9	58,9	1,2	19,8	22,3	51,8	1	14,1	17,6	44,7	0,77	14,6	12,8	37,4	0,56	8,2	7,7	29,7	0,34	9

- the air flow rates indicated correspond to the maximum, mean and minimum flow rates

Water heater parameters



ATAI-4-ECV3CL - HEATING

Inlet air temperature	Air flow	90/70				80/60				70/50				60/40				50/30			
		Heating capacity of the heater	Exhaust air temperature	Water flow	Pressure loss - water	Heating capacity of the heater	Exhaust air temperature	Water flow	Pressure loss - water	Heating capacity of the heater	Exhaust air temperature	Water flow	Pressure loss - water	Heating capacity of the heater	Exhaust air temperature	Water flow	Pressure loss - water	Heating capacity of the heater	Exhaust air temperature	Water flow	Pressure loss - water
°C	m3/h	kW	°C	m3/h	kPa	kW	°C	m3/h	kPa	kW	°C	m3/h	kPa	kW	°C	m3/h	kPa	kW	°C	m3/h	kPa
5	4400	65,9	55	2,9	35	57,5	47,7	2,53	30	48,8	40,4	2,14	22	39,7	33,1	1,73	16	30,2	25,8	1,31	11
	3150	51,5	60,4	2,27	24	45,1	52,4	1,98	19	38,5	44,4	1,68	15	31,5	36,4	1,37	12	24,1	28,4	1,04	9
	1800	33	68,6	1,45	12	29,1	59,6	1,28	10	25	50,7	1,09	9	20,7	41,7	0,9	7	16,1	32,7	0,7	6
10	4400	61,2	57,7	2,7	31	52,8	49,4	2,32	25	44	42,1	1,93	19	34,8	34,8	1,52	14	25,1	27,5	1,09	10
	3150	47,9	61,7	2,11	21	41,5	53,7	1,81	18	34,7	45,7	1,52	14	27,7	37,8	1,21	10	20,2	29,7	0,88	6
	1800	30,7	69,4	1,35	11	26,8	60,4	1,18	9	22,7	51,5	0,99	8	18,3	42,5	0,8	5	13,5	33,4	0,59	4
15	4400	56,6	58,4	2,49	28	48,1	51	2,11	21	39,2	43,7	1,84	15	30	39,4	1,31	11	20,1	29	0,87	6
	3150	44,3	63	1,95	18	37,8	55	1,66	14	31	47	1,49	11	23,8	39	1,04	9	16,2	30,9	0,7	6
	1800	28,5	70,2	1,25	9	24,5	61,2	1,08	9	20,4	52,3	1,01	6	15,8	43,2	0,69	6	11	34	0,48	3
18	4400	59,3	57,8	2,63	38,3	49	50,9	2,17	27,4	38,6	43,9	1,7	20,5	28,1	36,9	1,23	16,1	17,16	29,5	0,75	11,7
	3150	47,6	62,6	2,12	25,6	39,4	55	1,74	20,9	31,2	47,3	1,37	13,9	22,8	39,4	1	11	14,14	31,2	0,62	8,1
	1800	31,9	70,4	1,4	13,9	26,6	61,6	1,18	14,1	21,2	52,8	0,93	9,4	15,7	43,8	0,69	9,8	9,66	33,8	0,42	12,7

- the air flow rates indicated correspond to the maximum, mean and minimum flow rates

ATAI-4-ECV4CL - HEATING

Inlet air temperature	Air flow	90/70				80/60				70/50				60/40				50/30			
		Heating capacity of the heater	Exhaust air temperature	Water flow	Pressure loss - water	Heating capacity of the heater	Exhaust air temperature	Water flow	Pressure loss - water	Heating capacity of the heater	Exhaust air temperature	Water flow	Pressure loss - water	Heating capacity of the heater	Exhaust air temperature	Water flow	Pressure loss - water	Heating capacity of the heater	Exhaust air temperature	Water flow	Pressure loss - water
°C	m3/h	kW	°C	m3/h	kPa	kW	°C	m3/h	kPa	kW	°C	m3/h	kPa	kW	°C	m3/h	kPa	kW	°C	m3/h	kPa
5	4000	81,5	62,6	3,62	40,4	70,14	54,5	3,1	31,2	58,7	46,4	2,58	27,8	47,13	38,3	2,06	18,9	35,3	30	1,54	13,5
	2800	62,8	68,4	2,79	25,1	54,26	59,7	2,4	23,6	45,5	51	2	20,8	36,7	42,1	1,61	14,2	27,7	33	1,21	13
	1600	40,4	76,4	1,8	16,2	35,05	66,8	1,55	12,6	29,6	57,3	1,3	14,2	24,11	47,5	1,06	9,8	18,4	37,6	0,8	12
10	4000	75,2	64,1	3,34	34,9	64	56	2,83	26,4	52,6	47,8	2,32	22,8	41,1	39,6	1,8	17,6	29,4	31,1	1,28	14,5
	2800	58,05	69,6	2,58	26,4	49,5	60,8	2,19	20	40,9	52	1,8	17	32,1	43	1,41	11,1	23,1	33,8	1	9,3
	1600	37,3	77	1,66	13,9	32	67,5	1,41	10,6	26,6	57,8	1,17	11,7	21,15	48	0,93	7,7	15,45	37,7	0,67	8,6
15	4000	69,1	65,5	3,07	29,8	58	57,4	2,56	26,7	46,7	49,1	2	18,3	35,3	40,8	1,55	13,2	23,45	32,1	1	9,5
	2800	53,3	70,7	2,37	22,5	44,9	61,9	1,98	19,9	36,3	52,9	1,6	13,7	27,6	43,9	1,21	12,7	18,6	34,4	0,81	12,1
	1600	34,3	77,7	1,52	11,9	29	68	1,28	13,5	23,7	58,3	1	9,4	18,25	48,3	0,8	11,6	12,3	37,4	0,53	5,6
18	4000	65,5	66,4	2,91	27,1	54,4	58,2	2,41	23,8	43,23	49,9	1,9	18,9	31,7	41,5	1,39	10,9	19,82	32,6	0,86	7
	2800	50,5	71,3	2,25	20,4	42,1	62,5	1,86	17,7	33,64	53,5	1,48	11,9	29,9	44,3	1,09	10,5	15,7	34,6	0,69	8,9
	1600	32,5	78	1,45	10,8	27,3	68,4	1,21	12,1	21,9	58,6	0,97	8,2	16,5	48,5	0,72	9,6	10,2	36,9	0,45	4

- the air flow rates indicated correspond to the maximum, mean and minimum flow rates

Technical parameters of the ATACAMA Destratification unit

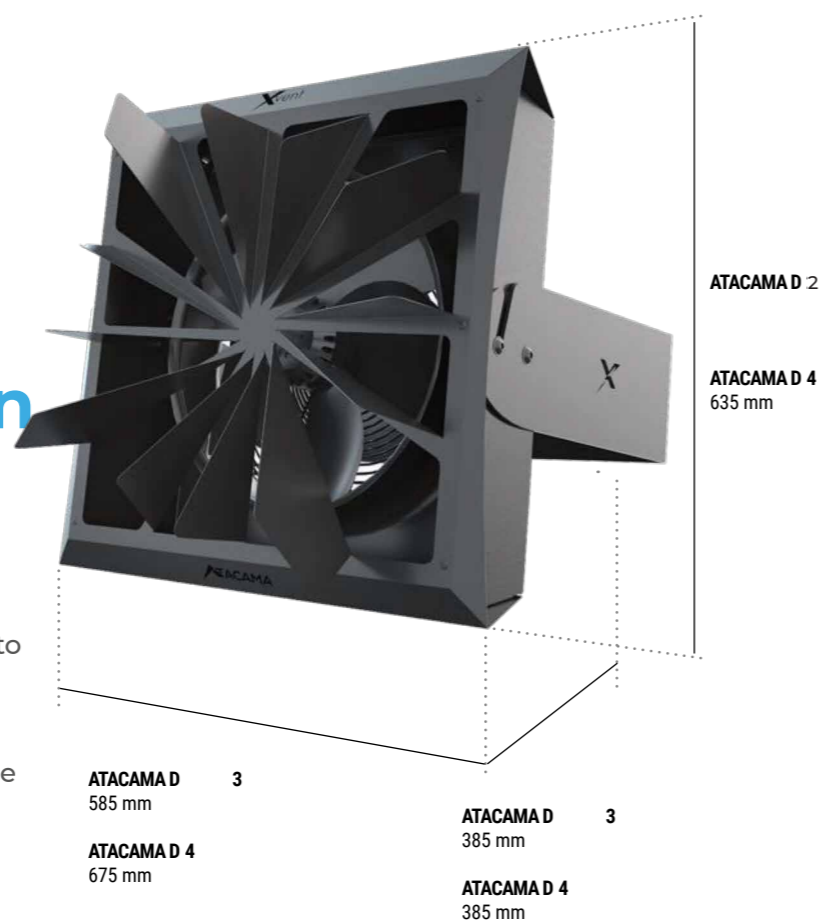

For the proper functioning of the destratification unit, it is necessary to bend the louvers by 90°, otherwise it is possible that the unit will not work properly, may damage the fan and cause excessive noise.

Technical data

NAME		ATACAMA 3 DESTRA	ATACAMA 4 DESTRA
Motor type	-	EC	EC
Service area (4m ceiling height)	m ²	0-500	0-1000
Air output	m ³ /h	3300	5000
Maximum vertical blowing range *	m	13	12
Noise level **	dB	52,9	52,6
Unit weight / with bracket	kg	11,5 / 14	16,5 / 19,5
Unit power supply	V/Hz	230/50-60	230/50-60
Motor power	W	110	337
Motor current	A	0,78	1,45
Cover	IP	54	54
Sales code	-	ATA1-3-ECS0DI-0A0	ATA1-4-ECS0DI-0A0

*Maximum range of air flow at 0,5m/s air speed

**Sound pressure level in 5m, Q=2

ATA1-3-ECS0DI

ATACAMA D 3 – PROVEDENÍ EC

Fan speed *	Air output m ³ /h	Current A/230V/Hz	Power Consumption W	Acoustic power in frequency bands (dB)								Noise level	
				63 Hz	125 Hz	250 Hz	500 Hz	1 kHz	2 kHz	4 kHz	8 kHz	LwA	LPA**
III	3350	32,00/230/50-60	110	28,4	49,1	54	62	64	62,8	55,7	45,3	68,3	43
II	2300	0,41/230/50-60	21	27,4	32,1	43,8	51,9	51,3	47,7	38,9	27,2	55,9	30,6
I	950	0,09/230/50-60	3	10	22,4	32,6	42,4	42,4	34,5	26,3	19,1	46	20,7

*The specified air flow rates correspond to the maximum, mean and minimum flow rates

** Sound pressure level in 5m, Q=2

ATA1-4-ECS0DI

ATACAMA D 4 – PROVEDENÍ EC

Fan speed *	Air output m ³ /h	Current A/230V/Hz	Power Consumption W	Acoustic power in frequency bands (dB)								Noise level	
				63 Hz	125 Hz	250 Hz	500 Hz	1 kHz	2 kHz	4 kHz	8 kHz	LwA	LPA**
III	5600	1,44/230/50-60	337	40,5	56,1	68,5	70,9	72,7	72,5	68	56,7	78	52,6
II	4200	0,62/230/50-60	151	34,9	48,4	57,5	64,4	66	65,3	59,1	46	70,6	45,3
I	2450	0,22/230/50-60	49	24,5	33,8	47	49,6	52,5	49,3	38,8	22,8	56,2	30,9

*The specified air flow rates correspond to the maximum, mean and minimum flow rates

** Sound pressure level in 5m, Q=2

Packaging

	Code	Weight		Package size *	max. number of units on the pallet** / max. stack capacity
		Brutto	Netto		
		kg	kg	m	ks
ATACAMA 3 DESTRA	A ATA1-3-ECS0DI-0-A-0	16,2	11,5	0,59x0,73x0,35	8/4
ATACAMA 4 DESTRA	A ATA1-4-ECS0DI-0-A-0	21,7	16,5	0,69x0,87x0,35	8/4

*The package size is indicated in the order of width x length x height



More information



Xvent s.r.o.
Poděbradská 289,
53009 Pardubice
Czech Republic

+420 467 070 233
office@xvent.cz

www.xvent.cz